

# PMR05D Series

5W, Encapsulated AC/DC Power Converters



## Features

- Rated power: 5W Max
- Universal input: 85~305VAC 47~63Hz
- Regulated single output
- Isolation voltage 4000VAC
- Typical efficiency 70 ... 79%
- Energy saving, standby power only less than 0.1W
- Operating temperature range: -40~+85°C
- RoHS compliance
- Compact 1"x1" package
- Low profile 15mm height
- Over voltage, over current and short circuit protection
- \*Designed to meet UL/IEC/EN62368, EN60335, EN61558, CISPR32, EN55032 Class B
- 3 year warranty



\*Certification is process, scheduled to complete in Sep, 2024.

## Overview

PMR05D series are compact size AC/DC power converters offered in 1"x1" package and extremely low profile. The series also feature universal input voltage range, low stand by power consumption, high efficiency. Designed for high reliability industrial applications, these converters are encapsulated to protect from dust and moisture. They are designed to meet IEC/EN/UL62368, EN60335, EN61558, and EMC performance meets CISPR32, EN55032 Class B, ideally suitable for industrial, and critical commercial applications.

## Model Numbers

Model Number	Input Voltage [VAC]	Output Voltage [VDC]	Output Current [mA] Max.	Efficiency [%] Typ.	Capacitive Load [uF] Max.
PMR05D-033	85~305VAC 100~430VDC	3.3	1200	70	4000
PMR05D-050		5	1000	74	3000
PMR05D-090		9	555	78	1200
PMR05D-120		12	416	79	1200
PMR05D-150		15	333	79	680
PMR05D-240		24	208	79	220

\* Only typical models are listed, other models may be available, upon request.

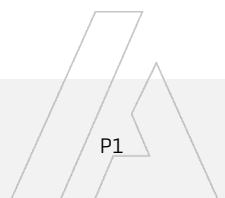

## Electrical Specifications

Unless otherwise indicated, specifications are measured at  $T_A=25^{\circ}\text{C}$ , humidity<75%, nominal input voltage and rated output load.

Parameters	Condition	Min.	Typ.	Max.	Unit	Note
Input voltage range	AC in	85	-	305	VAC	
	DC in	100	-	430	VDC	
Input frequency		47	-	63	Hz	
Nominal input voltage		100	-	277	VAC	
Input current	115VAC	-	-	0.13	A	
	230VAC	-	-	0.07	A	
Inrush current Cold start	115VAC	-	15	-	A	
	230VAC	-	25	-	A	
Leakage current	277VAC, 50Hz	-	-	0.25	mA RMS	
Output voltage accuracy	$V_{OUT}=3.3\text{V}$	-	$\pm 3$	-	%	
	Others	-	$\pm 2$	-	%	
Line regulation	Full load	-	$\pm 0.5$	-	%	
Load regulation $I_{OUT}=0\% \sim 100\%$ of $I_{OUT, rated}$		-	$\pm 1.0$	-	%	
Ripple and noise 20MHz bandwidth, peak to peak		-	50	100	mV	
Temperature coefficient		-	$\pm 0.02$	-	%/ $^{\circ}\text{C}$	
Standby power consumption	230VAC	-	0.1	-	W	
Hold up time Full load	115VAC	-	5	-	mS	
	230VAC	-	50	-	mS	
Over voltage protection Hiccup or clamping by Zener diode	$V_{OUT}=3.3, 5\text{V}$	-	-	7.5	VDC	
	$V_{OUT}=9, 12\text{V}$	-	-	17		
	$V_{OUT}=15\text{V}$	-	-	20		
	$V_{OUT}=24\text{V}$	-	-	30		
Over current protection	Automatic recovery	110	-	-	% $I_{OUT}$	
Short circuit protection		Continuous, hiccup mode, automatic recovery				
Recommended external fuse		1A, 300V, slow blow, *required*				
Minimum load		No minimum load is required				

\* Ripple and noise measured at 20MHz of bandwidth by using a 12" twisted pair-wire terminated with a 1uF ceramic capacitor and a 10uF electrolytic capacitor in parallel.

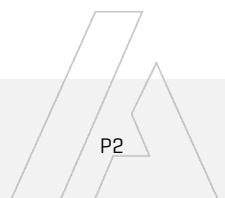

## General Specifications

Parameters	Condition	Min.	Typ.	Max.	Unit	Note
<b>Isolation voltage</b> 1 minute, leakage current 5mA max	I/P to O/P	4000	-	-	VAC	
<b>Isolation resistance</b> 500VDC, 25°C, 70%RH	I/P to O/P	100	-	-	M Ohm	
<b>Switching frequency</b>		-	65	-	KHz	
<b>Operating temperature range</b>	See "Derating Curve"	-40	-	85	°C	
<b>Storage temperature</b>		-40	-	105	°C	
<b>Storage humidity</b>		10	-	95	%RH	
<b>Operating altitude</b>		-	-	5000	m	
<b>Soldering temperature</b>	Wave Manual	-	260 360	-	°C	
<b>Case material</b>		Black plastic UL94-V0				
<b>Cooling method</b>		Free air convection				
<b>Vibration</b>		10Hz to 55Hz, 10G, 30 minutes along X, Y and Z axis				
<b>Class II power</b>		Yes, no FG				
<b>MTBF</b>	MIL-HDBK-217F	> 260,000 Hours, 25°C				
<b>Design based on standards</b>		RoHS5 compliant, UL/IEC/EN62368, EN60335, EN61558				
<b>Safety certifications*</b>		UL/EN/IEC 62368, EN60335, EN61558				
<b>EMC</b>		CISPR32, EN55032 Class B				
<b>Size, and Weight</b>		25.4 x 25.4 x 15 mm, 16g				

\*Certification is process, scheduled to complete in Sep, 2024.

## Characteristic Curves

### Derating Curves

Output vs Ambient Temperature

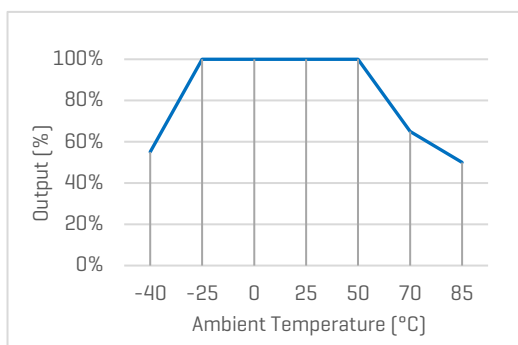

Output vs Input Voltage

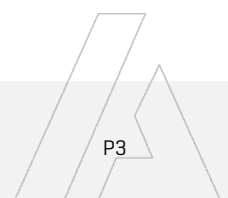
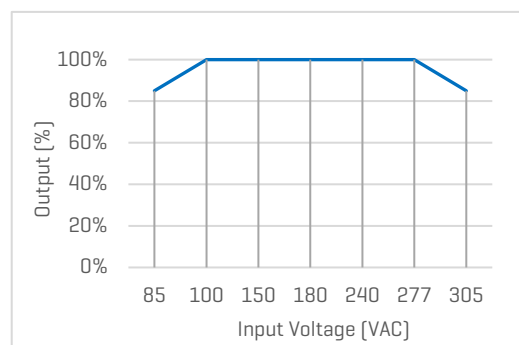

## Recommended External Circuits

### Typical External Circuit

\*Components with "\*" are required. The other components are highly recommended.

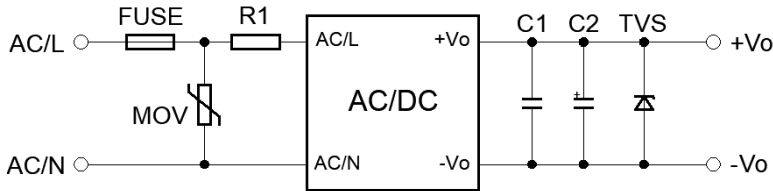

Figure 1. Typical external circuit

### Recommended Components [Table 1]

SPEC	FUSE*	MOV	R1*	C1	C2	TVS
V <sub>out</sub> =3.3, 5V	1A, 300V	10D681K	12 Ohm, 3W	1uF, 50V	150uF, 16V	SMBJ7.0A
V <sub>out</sub> =9V	1A, 300V	10D681K	12 Ohm, 3W	1uF, 50V	120uF, 35V	SMBJ12A
V <sub>out</sub> =12, 15V	1A, 300V	10D681K	12 Ohm, 3W	1uF, 50V	120uF, 35V	SMBJ20A
V <sub>out</sub> =24V	1A, 300V	10D681K	12 Ohm, 3W	1uF, 50V	68uF, 35V	SMBJ30A

\* For further questions contact one of our sales representatives.

### EMC Enhancement for EN55032 Class B

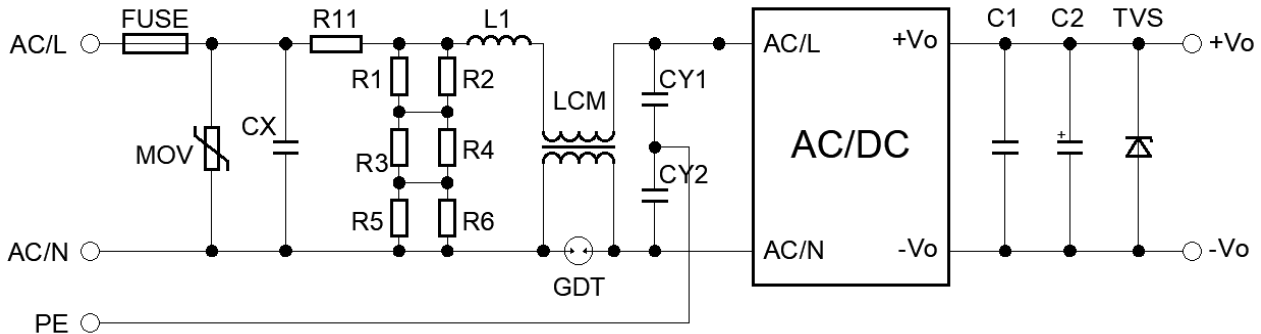

Figure 1. Circuit for EMC Enhancement

### [Table 2] Recommended Components

MOV	CX	R11	L1	LCM	GDT	CY1, CY2
14D681K	334K, 305VAC	33 Ohm, 3W	1.2mH, 0.3A	20mH	300V, 1KA	1nF, 400VAC

\*FUSE to be 2A, 300V, slow blow. \*R1 ... R6 is the bleeder resistance of CX - 1.5Mohm, 150VDC

\*Other components see the same in Table 1

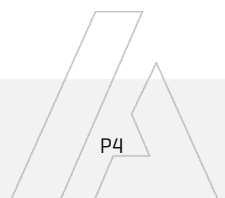

## Mechanical Specifications

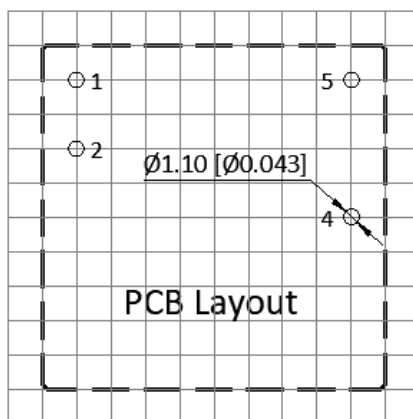
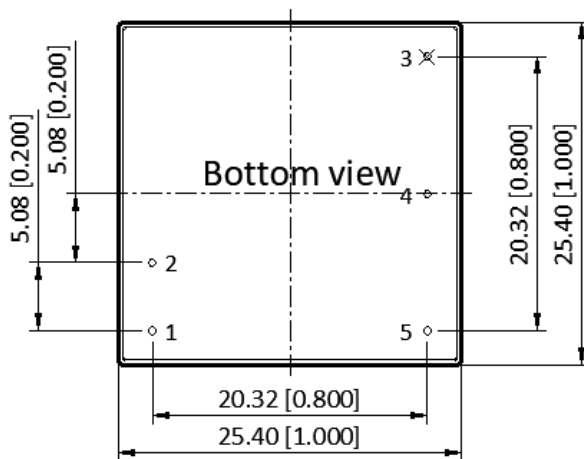
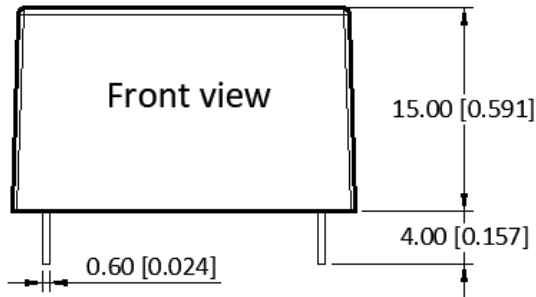

### Pin Definition

Pin #	Single Out
1	AC [N]
2	AC [L]
3	No Pin
4	-V <sub>OUT</sub>
5	+V <sub>OUT</sub>

\* Unless otherwise specified unit: mm [inch]

\* General tolerance: ±0.50 [±0.020]

\* Pin thickness: ±0.15 [±0.006]

\* Pin distance: ±0.50 [±0.020]

\* Footprint grid 2.54 x 2.54 mm